

# Southco® Push to Close Latches

## Touch Latch, Large Size

- Push the door to latch and unlatch
- Single-hole, snap-in installation
- Self-adhesive keeper
- Nothing shows on the surface

LATCH

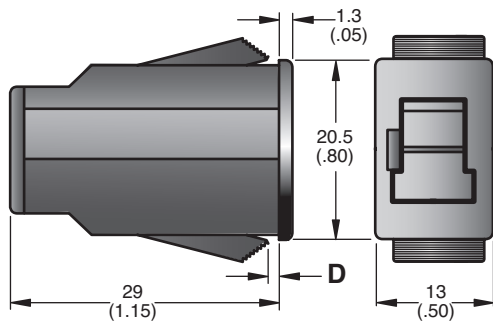

KEEPER ASSEMBLY

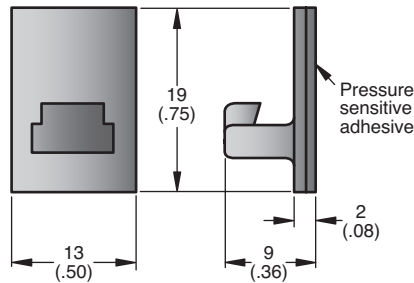

FRAME THICKNESS		D	PART NUMBER
MIN.	MAX.		
1 (.04)	3 (.12)	0.9 (.035)	E4-10-201-10 •
3 (.12)	5 (.20)	2.9 (.115)	E4-10-202-10 •
5 (.20)	7 (.28)	4.9 (.195)	E4-10-203-10



Latched

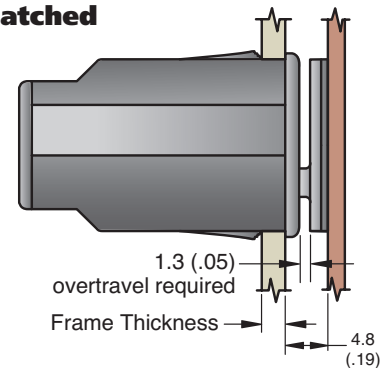

### Material and Finish

SPRING: 302 Stainless steel, passivated.  
 PRESSURE SENSITIVE TAPE: Neoprene foam with acrylic adhesive.  
 HOUSING and COVER: Thermoplastic polyester, black.  
 OTHER PARTS: Acetal, black.

### Product Strength Guidelines

(To assist in your product selection; samples are available for your evaluation.)

Average latch tensile with:  
 Standard adhesive keeper 50 N (11 lbs.)  
 Integrally molded keeper 120 N (27 lbs.)

**Flammability Rating:** UL94 - HB  
**Operating Temperature Range:**  
 -40°C (-40°F) to 105°C (220°F)

NOTE: Self-adhesive keepers are designed to function under intermittent break-away loads.

NOTE: Be sure the mounting surface is clean and capable of retaining a satisfactory adhesive bond.

## Installation

1. Prepare frame.

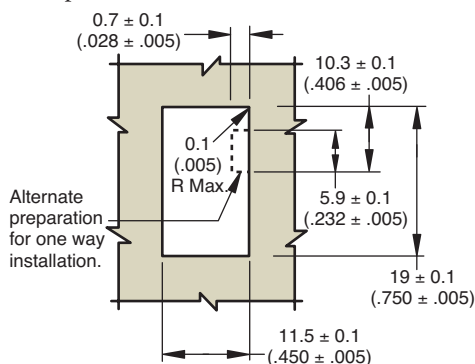

2. Snap latch into place.

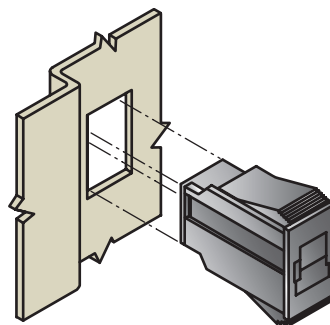

3. Re-engage keeper with latch.

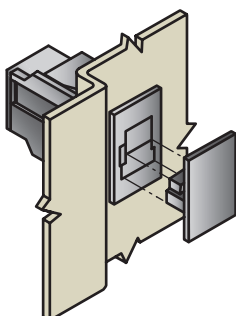

4. Peel protective backing from keeper. Close door against adhesive.

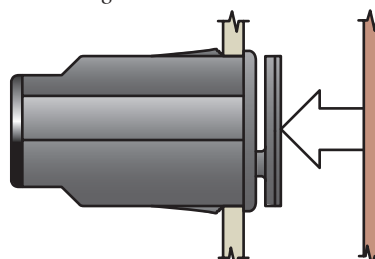

millimeter (inch)  
 millimeter  
 (inch)

Dimensions without tolerances are for reference only.