

Southco® Push to Close Latches

Corrosion-resistant, Push-button Style

- Push the button to unlatch
- Locking and non-locking styles available
- Optional ejector spring helps prevent rattles



Material and Finish

HOUSING: Glass reinforced nylon, black. PAWL: Acetal, black. KNOB and KNOB PLUG: Polyester, black. LOCK PLUG: Glass reinforced acetal, black. CAM: Glass reinforced nylon/silicone, black. INTERNAL SPRINGS: 302 Stainless steel, natural. PULL TAB: Nylon, black or CF-8M stainless steel. MOUNTING NUT: Glass reinforced nylon, black. LOCKWASHER: 302 Stainless steel, passivated. KEEPER: 304 Stainless steel, passivated. EJECTOR SPRING: 1065 steel, black organic coating.

Product Strength Guidelines

(To assist in your product selection; samples are available for your evaluation.)
 Maximum working load: 530 N (120 lbs.)
 Ultimate load: 690 N (155 lbs.)

Installation

(see below)

1. Prepare panel and frame.
2. Insert latch through Pull Tab (optional) and into hole.
3. Add lockwasher and mounting nut and optional ejector spring if desired.
4. Install keeper and adjust for proper latching.

millimeter (inch)
 millimeter (inch)

Dimensions without tolerances are for reference only.

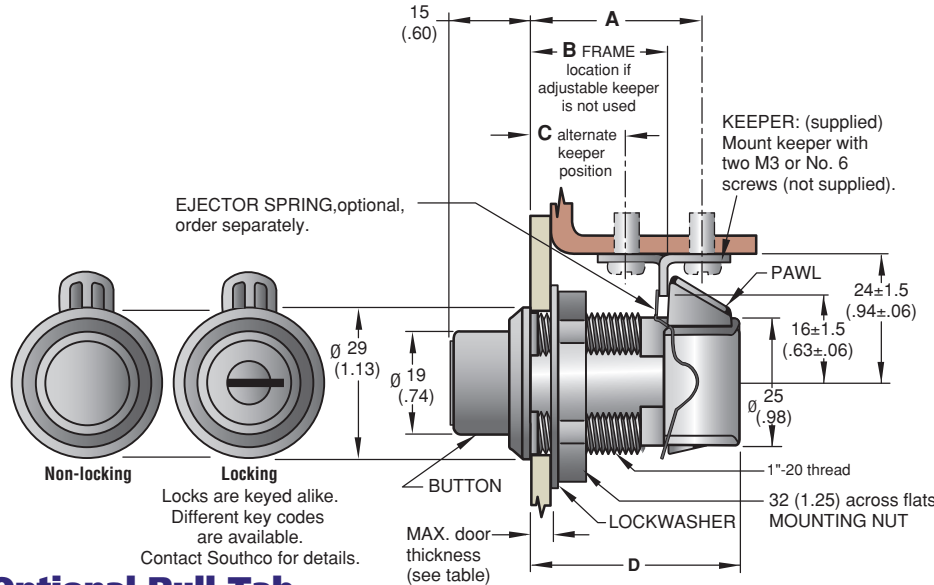

Optional Pull Tab

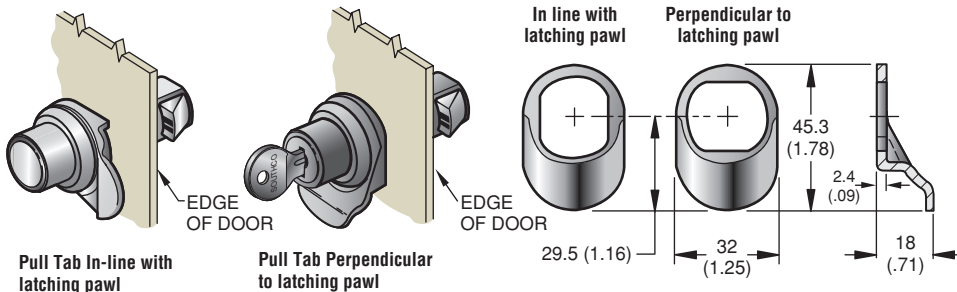

Pull Tab In-line with latching pawl

Pull Tab Perpendicular to latching pawl

STYLE	Max. door thickness	A	B	C	D REF.
Latch only	12.7 (.500)	32±1.5 (1.25±.06)	25±0.4 (1.000+0.000-0.032)	17±1.5 (.66±.06)	40 (1.57)
Latch with pull tab	10.3 (.407)	29.5±1.5 (1.16±.06)	23 ^{+0.1} _{-0.7} (.907+0.000-0.032)	14.5±1.5 (.57±.06)	37 (1.47)

PART NUMBERS	Keylock	Non-keylock
Pull tab in line with latching pawl.	93-303 •	93-304 •
Pull tab perpendicular to latching pawl.	93-313 •	93-314 •
Latch only.	93-307 •	93-308 •
Ejector Spring (if required)	93-22-302-18 •	

