

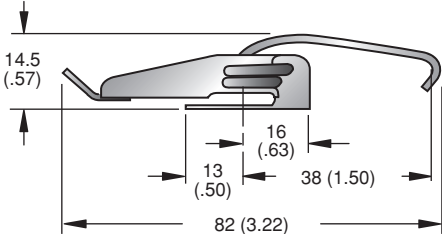





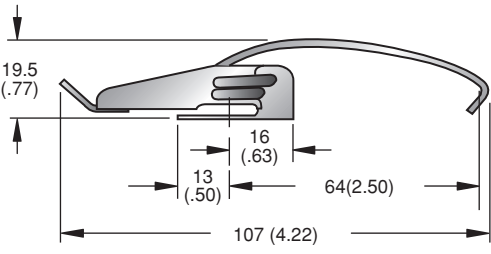

Southco® Draw Latches

Versa Latch Series, Small and Medium Size

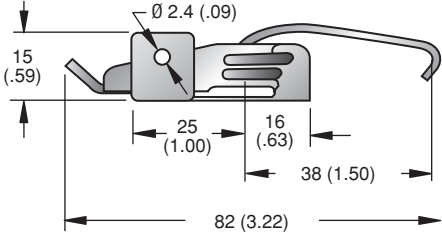
- For applications where latch and keeper remain on the same plane
- Torsion springs accommodate application variances
- Long and short blade options
- Pad-lockable version for added security
- Wire sealing version
- Steel or Stainless Steel

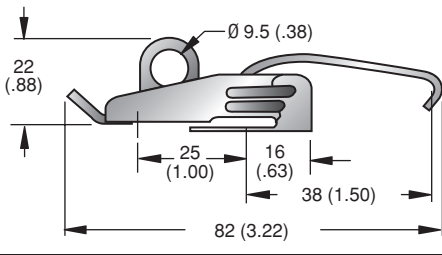
LATCH BODY TYPE	LATCH SPECIFICATIONS	S		PART NUMBERS	
		MIN.	MAX.	STEEL	STAINLESS
SMALL	SHORT BLADE  	*55 (2.17)	*57.3 (2.26)	V2-0025-07 •	V2-0025-52 •
	LONG BLADE  	80.7 (3.17)	*83 (3.26)	V2-0068-07 •	_____
	WIRE SEALING  	*55 (2.17)	*57.3 (2.26)	V2-0034-07 •	V2-0034-52 •
	PADLOCKABLE  	*55 (2.17)	*57.3 (2.26)	V2-0026-07 •	V2-0026-52 •
MEDIUM	LONG BLADE  	*96.7 (3.80)	*99 (3.90)	V3-0072-07 •	_____

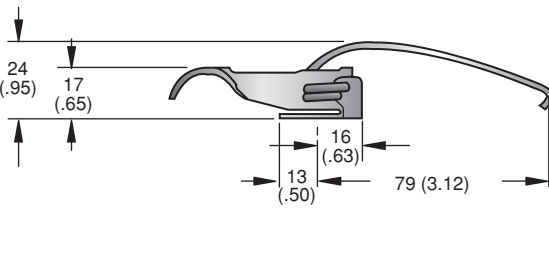
Draw Latches
Steel/Stainless Steel

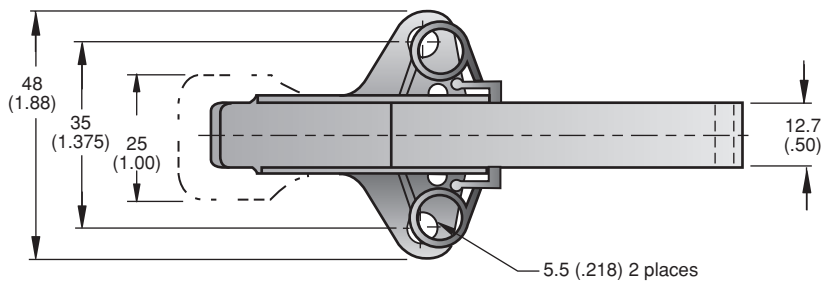

Keepers

(For all Small and Medium Size Latches)

KEEPER DIMENSIONS	Ø D	STEEL	STAINLESS STEEL
	3.4 (.135)	V2-0018-07 •	V2-0018-52 •
	5.5 (.218)	V2-0054-07 •	V2-0054-52 •

Suggested Mounting Dimensions

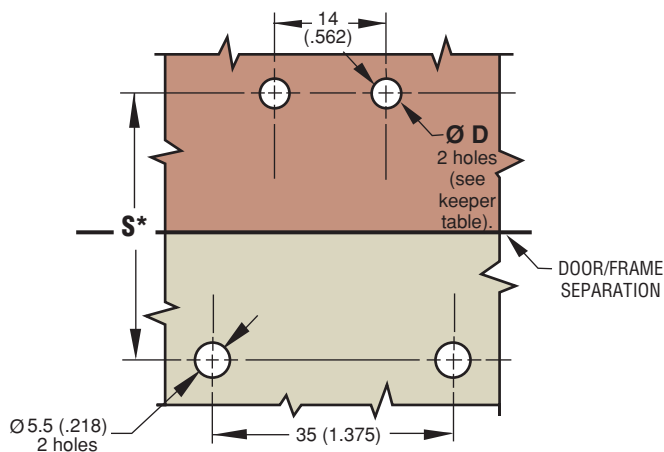

***Note:** Spring loaded anchor plate compensates up to 2.3 (0.09) for irregularities in sealing and gasket set.

Material and Finish

Small:

ANCHOR PLATE and HANDLE : Carbon steel, zinc plated plus bright chromate dip.

LONG BLADE: Spring steel, zinc plated plus bright chromate dip.

SHORT BLADE: Carbon steel, zinc plated plus bright chromate dip.

SPRINGS: Spring steel, zinc plated plus bright chromate dip.

Stainless Steel Version: 300 Series stainless steel.

Medium:

ANCHOR PLATE and HANDLE : Carbon steel, zinc plated plus bright chromate dip.

BLADE: Spring steel, zinc plated plus bright chromate dip.

SPRINGS: Spring steel, zinc plated plus bright chromate dip.

Product Strength Guidelines

(To assist in your product selection; samples are available for your evaluation.)

Steel

Clamping Force:

330 N (75 lbs.) MIN.,

700 N (160 lbs.) MAX.

Average ultimate load: 1770 N (400 lbs.)

Stainless Steel

Clamping Force:

260 N (60 lbs.) MIN.,

530 N (120 lbs.) MAX.

Average ultimate load: 1690 N (380 lbs.)

millimeter (inch)
millimeter
(inch)

Dimensions without tolerances are for reference only.