

CONNECTOR SYSTEMS

SMART CARD

TABLE OF CONTENTS

SCC01 Series Modular System.....	479-480
SCC01 Series Integral System.....	481
SCC02 Series Integral System with Landing Contact	482
SCC10 Series Modular System	483-484
Application Information	485

DESCRIPTION/APPLICATION

Thomas & Betts Smart Card Connectors (SCC) excel by their superior design and their high manufacturing quality.

These proprietary designs and manufacturing developments represent a technical revolution providing virtually unlimited applications:

Cellular phones, vending machines, public phones, toll collection systems, security, set-top box applications (pay tv), access control...

Benefit from T&B's worldwide resources and innovative ideas of our Smart Card Connector experts.

DESIGN ADVANTAGES

- Unique modular systems and integral systems allow the system designer added flexibility.
- Reading units and card guides meet the requirements of ISO 7810/7816 and GSM 11.11 standards.
- Low profile design minimizes space requirements.
- High temperature thermoplastic insulators are compatible with IR, and Vapor phase soldering processes.
- Contacts are designed for long life, minimizing card insertion force, yet insuring desirable card retention features.
- Precision molding, assembly, and testing minimize variation, thus insuring consistent and reliable connector properties.
- Special product designs can be developed on customer request.

SMART CARD CONNECTORS (SCC) ISO 7810/7816 AND GSM 11.11

**SCC INDEX**

Modular Reading Unit & Frame.....	2-3
Integral SCC – Sliding Contact.....	4
Integral SCC – Landing Contact	5
Modular Mini Sim Reading Unit & Frame	6-7

SCC01 SERIES MODULAR SYSTEM STANDARD READING UNIT WITH SWITCH OPTION



STANDARDS

FOR CARD: ISO 7810/7816

PHYSICAL PROPERTIES

COLOR: Blue
 LIFETIME: > 50,000 mating cycles
 INSULATION MATERIAL: High Temp. Polymer, UL94 V-0
 CONTACT MATERIAL: Cu alloy
 CONTACT PLATING: Au over Ni
 CONTACT FORCE: (0.3 - 0.5)N each contact
 SWITCH: Normally open

ELECTRICAL PROPERTIES

VOLTAGE RATING: 50 V max
 CURRENT RATING: 10 μ A min, 1 A max.
 CONTACT RESISTANCE: < 100 milliohm
 INSULATION RESISTANCE: > 10³ megohm

ENVIRONMENTAL PROPERTIES

APPLICATION TEMPERATURE: -40°C to +85°C
 STORAGE TEMPERATURE: -55°C to +110°C
 REFLOW SOLDERING: 240°C, 15 sec.

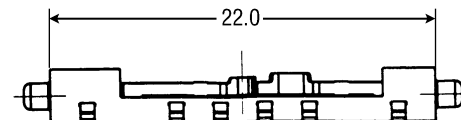
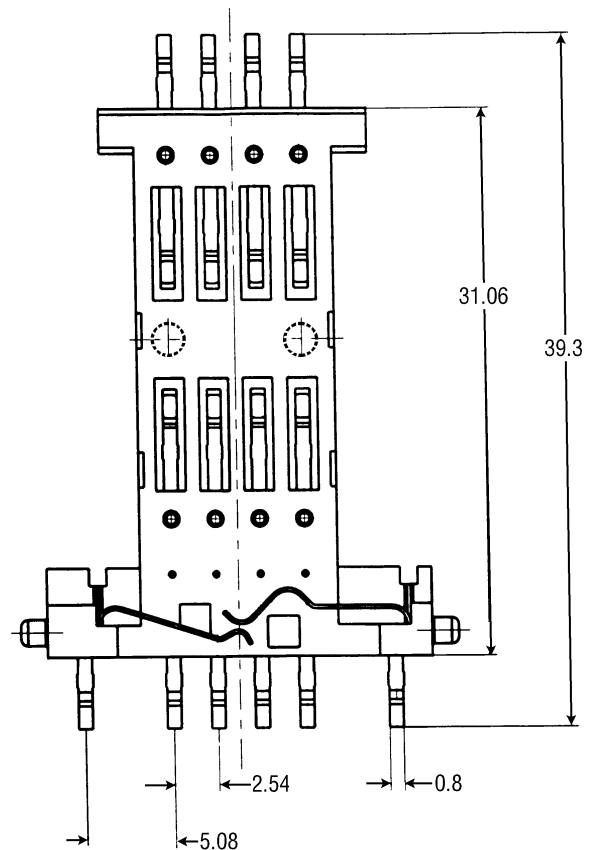
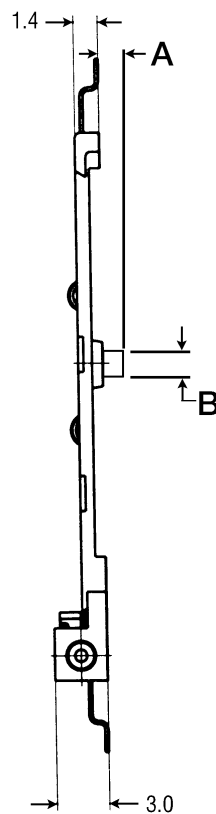
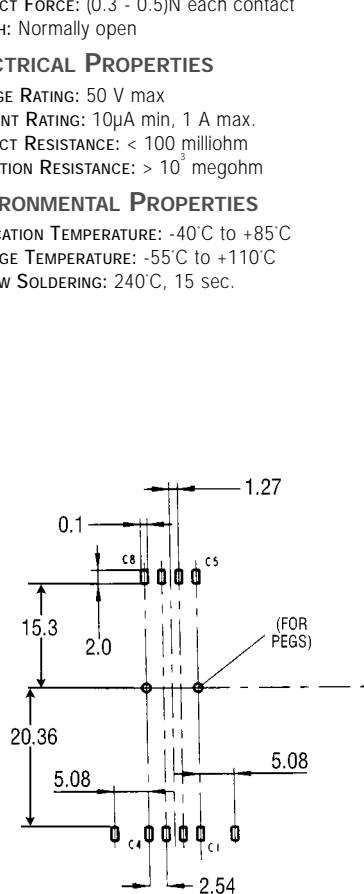

Ordering Information

CAT. #	DESCRIPTION	DIM A	DIM B
SCC01-002-08310	Standard reading unit, without switch	-	-
SCC01-003-08310	Standard reading unit, with switch	-	-
SCC01-005-08310	Standard reading unit, with switch, with pegs	1mm	1.2mm
SCC01-006-08310	Standard reading unit, without switch, with pegs	1mm	1.2mm



SCC01 SERIES MODULAR SYSTEM STANDARD FRAME



STANDARDS

FOR CARD: ISO 7810/7816

PHYSICAL PROPERTIES

COLOR: Black

INSULATION MATERIAL: High Temp. Polymer, UL94 V-0

ENVIRONMENTAL PROPERTIES

APPLICATION TEMPERATURE: -40°C to +85°C

STORAGE TEMPERATURE: -55°C to +110°C

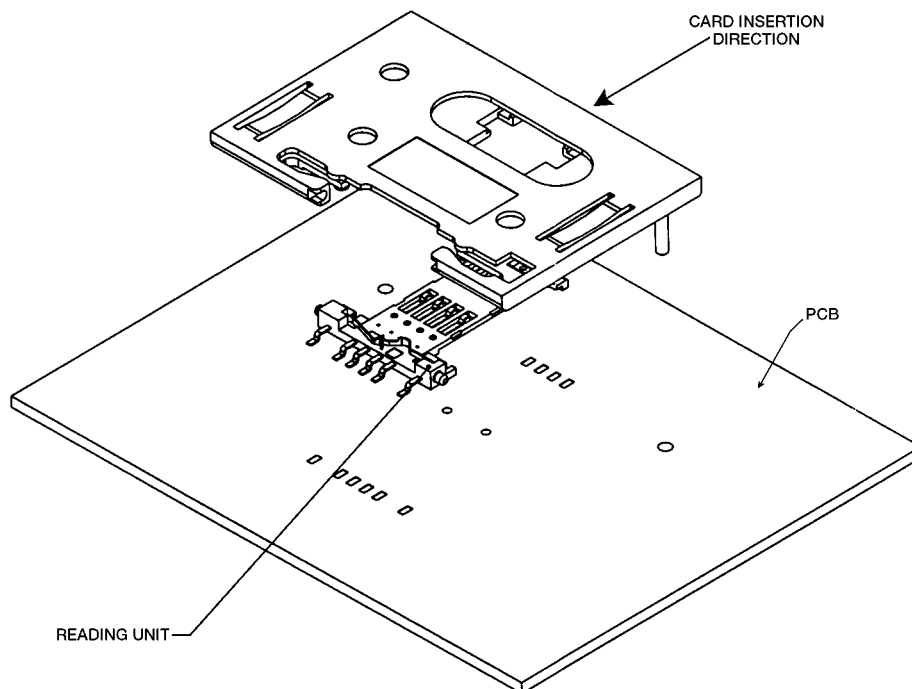
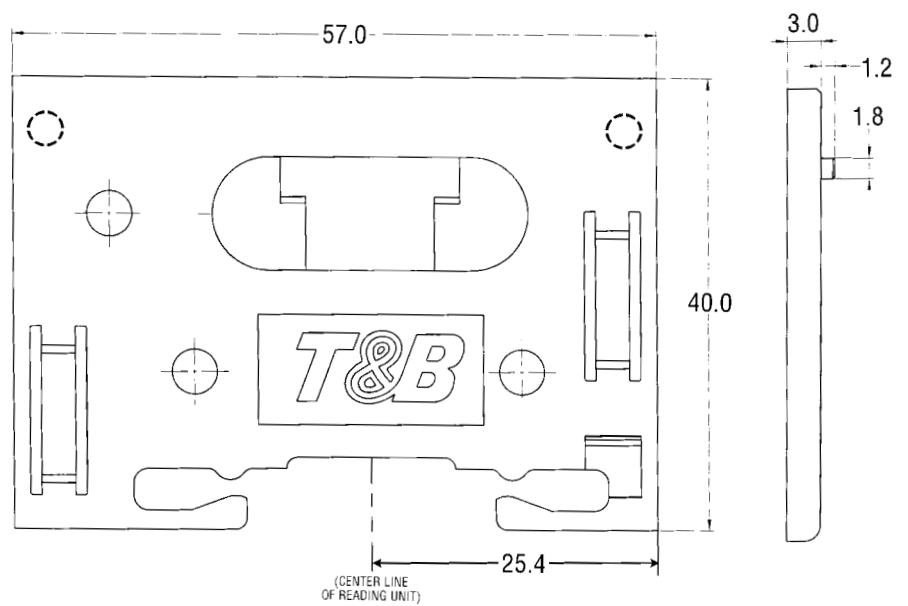
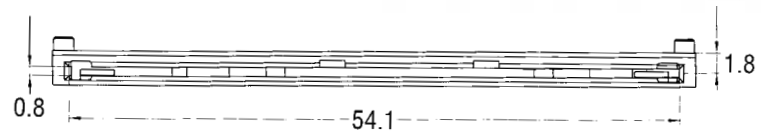

Ordering Information

CAT. #	DESCRIPTION
SCC01-200	Card Frame

INTEGRAL SYSTEM WITH SLIDING CONTACT

8 AND 16 POSITION



STANDARDS

FOR CARD: ISO 7810/7816

PHYSICAL PROPERTIES

COLOR: Black
 LIFETIME: > 100,000 mating cycles
 INSULATION MATERIAL: High Temp. Polymer, UL94 V-0
 CONTACT MATERIAL: Cu alloy
 CONTACT PLATING: Au over Ni
 CONTACT FORCE: (0.3 - 0.5)N each contact
 SWITCH: Normally open

ELECTRICAL PROPERTIES

VOLTAGE RATING: 50 V max
 CURRENT RATING: 10µA min, 1 A max.
 CONTACT RESISTANCE: < 100 milliohm
 INSULATION RESISTANCE: > 10³ megohm

ENVIRONMENTAL PROPERTIES

APPLICATION TEMPERATURE: -40°C to +85°C
 STORAGE TEMPERATURE: -40°C to +100°C
 MANUAL SOLDERING: 350°C, 2 sec.
 WAVE SOLDERING: 260°C, 5 sec.

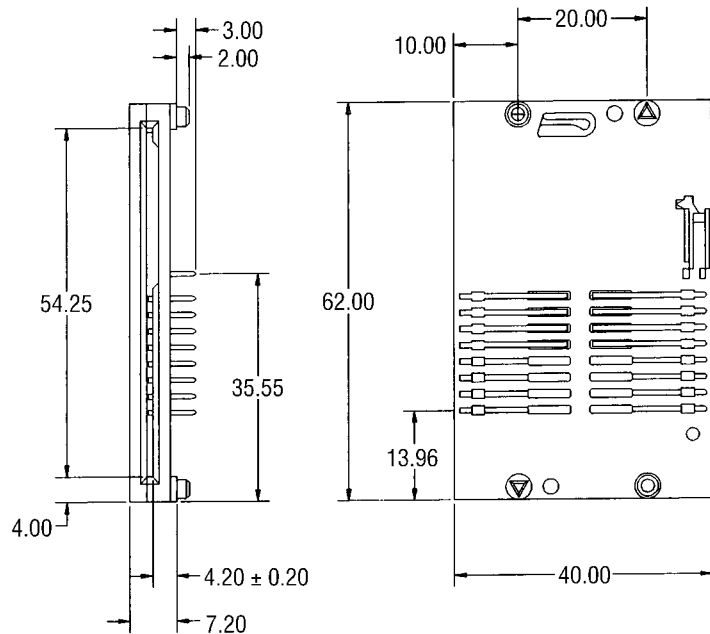

Recommended Hole Pattern

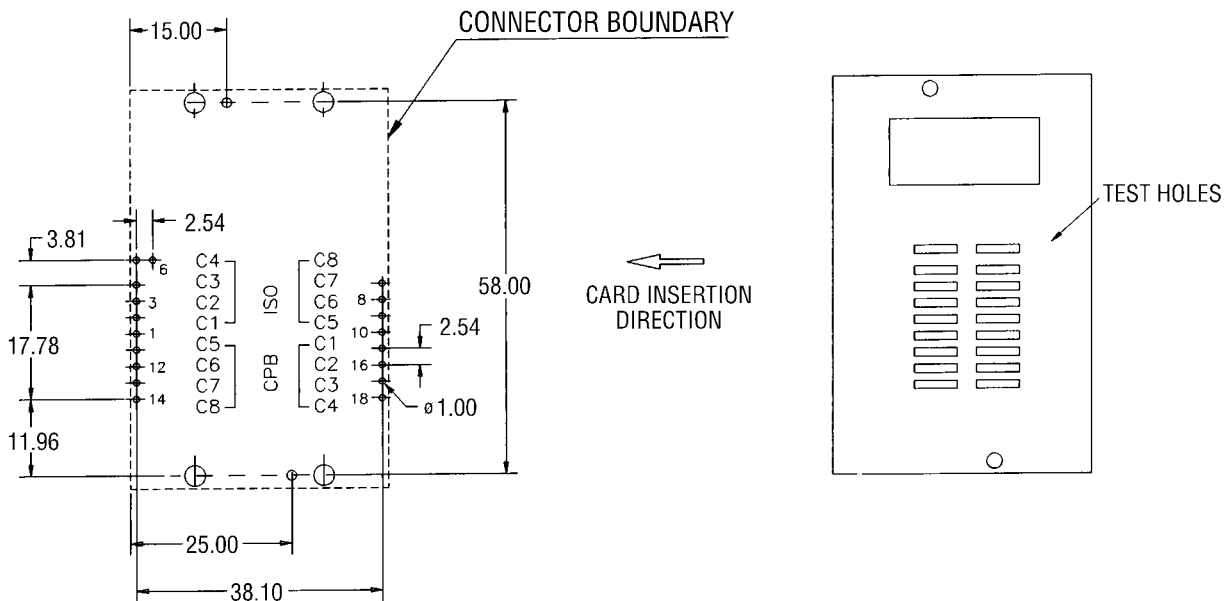

Ordering Information

CAT. #	# OF POSITIONS
SCC01-312-08320	8
SCC01-312-16320	16



SCC02 SERIES INTEGRAL SYSTEM WITH LANDING CONTACT

8 POSITION



STANDARDS

FOR CARD: ISO 7810/7816

PHYSICAL PROPERTIES

COLOR: Black
 LIFETIME: > 250,000 mating cycles
 INSULATION MATERIAL: High Temp. Polymer, UL94 V-0
 CONTACT MATERIAL: Cu alloy
 CONTACT PLATING: Au over Ni
 CONTACT FORCE: (0.3 - 0.5)N each contact

ELECTRICAL PROPERTIES

VOLTAGE RATING: 50 V max
 CURRENT RATING: 10µA min, 1 A max.
 CONTACT RESISTANCE: < 100 milliohm
 INSULATION RESISTANCE: > 10¹¹ milliohm

ENVIRONMENTAL PROPERTIES

APPLICATION TEMPERATURE: -40°C to +85°C
 STORAGE TEMPERATURE: -55°C to +110°C
 REFLOW SOLDERING: 240°C, 15 sec.

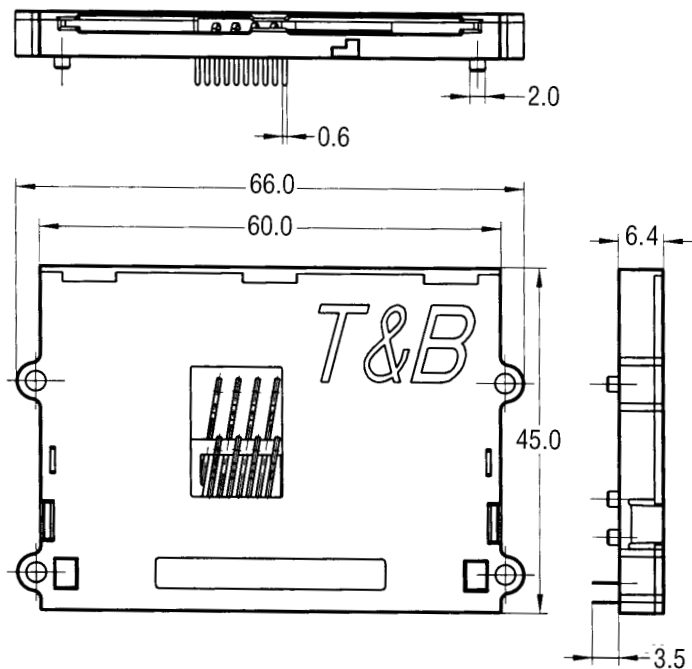

Recommended Hole Pattern

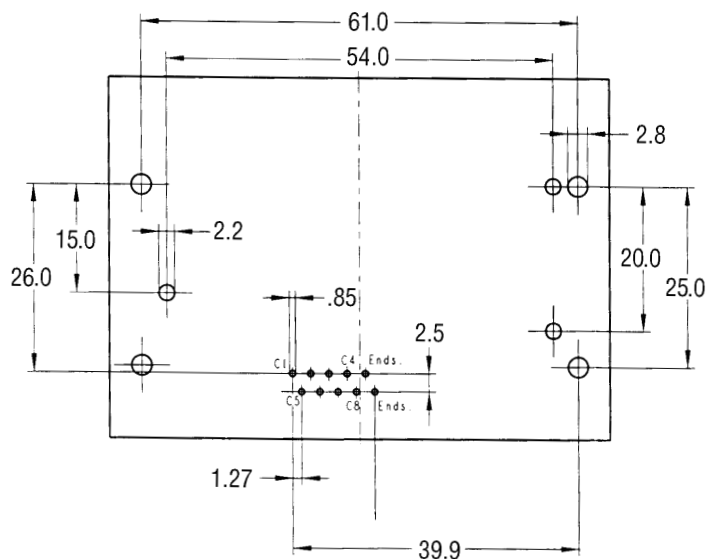

Ordering Information

CAT. #

SCC02-050-08420

SCC10 SERIES MODULAR SYSTEM MINISIM FRAME



STANDARDS

FOR CARD: ISO 7810/7816 and GSM 11.11 (SIM)

PHYSICAL PROPERTIES

COLOR: Black

LIFETIME: 50,000 cycles

INSULATION MATERIAL: High Temp. Polymer, UL94 V-0

ENVIRONMENTAL PROPERTIES

APPLICATION TEMPERATURE: -40°C to +85°C

STORAGE TEMPERATURE: -55°C to +110°C

REFLOW SOLDERING: 240°C, 15 sec.

MATES WITH: SCC10 Reading Units

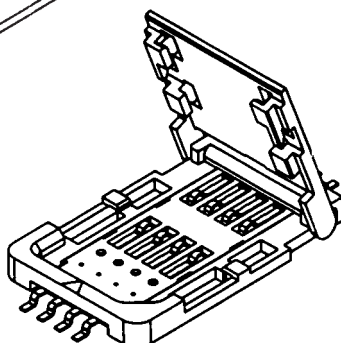
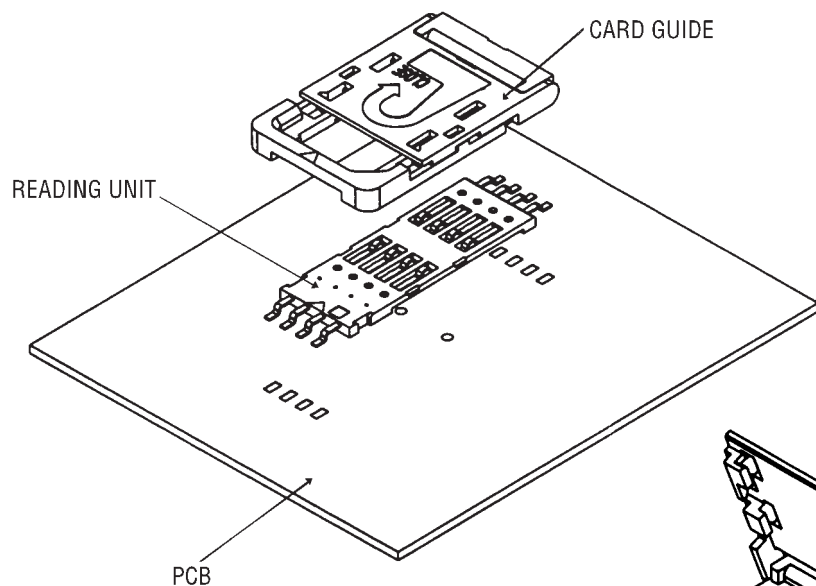
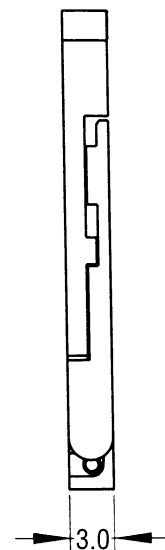
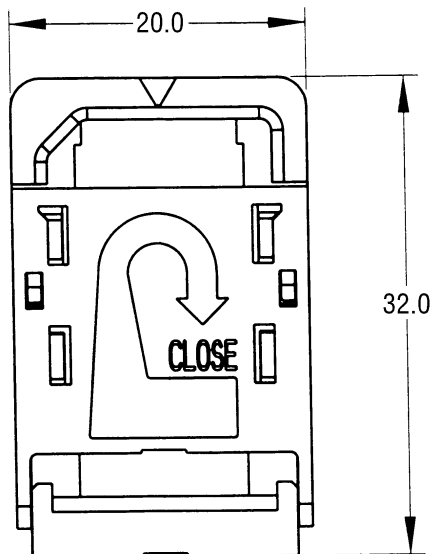

Insert Card
Into Cover

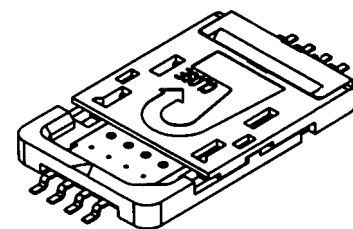

Close To Initiate
Connection

Ordering Information

CAT. #

SCC10-100

Product Application Information

TELECOMMUNICATIONS TELEPHONY

- Public Phones
- Cellular Phones
- Mobile Phones
- GSM / PCS



SCC01 MODULAR	SCC01 INTEGRAL SLIDING CONTACT	SCC02 INTEGRAL LANDING CONTACT	SCC10 MODULAR SLIDING CONTACT
------------------	--------------------------------------	--------------------------------------	-------------------------------------

SECURITY

- Physical Access (badges)
- Data Access
- Data Processing
- ID's



ENCRYPTION

- Satellite Television
- Cable Television
- Private Channels
- Games



PAYMENT

- Point of Sales Terminals
- Parking Meters
- Counters
- Electronic Purses



Card Contact Location and Dimensions

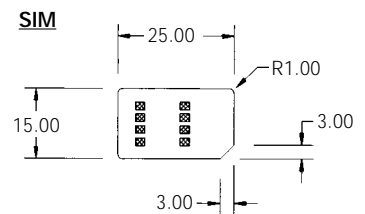
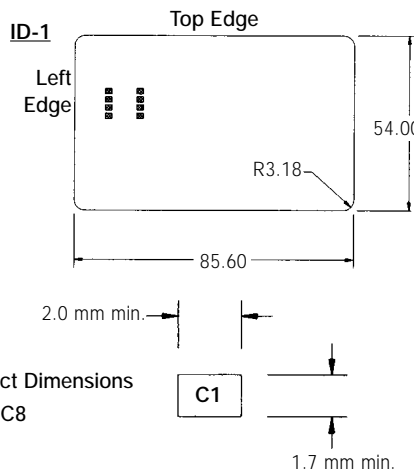
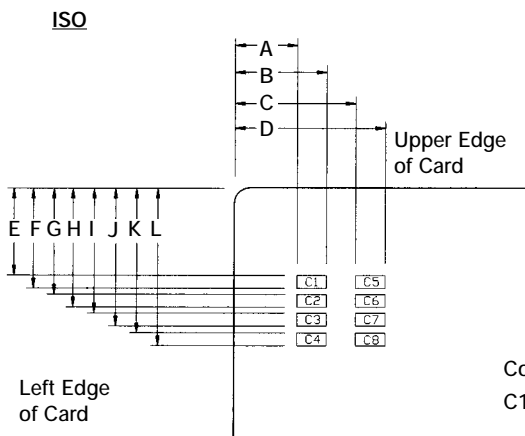

ISO 7816 DIMENSIONS (MM)

A = 10.25 max.
B = 12.25 min.
C = 17.87 max.
D = 19.87 min.
E = 19.23 max.
F = 20.93 min.
G = 21.77 max.
H = 23.47 min.
I = 23.31 max.
J = 26.01 min.
K = 26.85 max.
L = 28.55 min.

CP8 POSITION DIMENSIONS (MM)

A = 10.25 max.
B = 12.25 min.
C = 17.87 max.
D = 19.87 min.
E = 9.07 max.
F = 10.77 min.
G = 11.61 max.
H = 13.31 min.
I = 14.15 max.
J = 15.85 min.
K = 16.69 max.
L = 18.39 min.

SIM DIMENSIONS (MM)

A = 4.0 max.
B = 6.0 min.
C = 11.62 max.
D = 13.62 min.
E = 2.75 max.
F = 4.45 min.
G = 5.29 max.
H = 6.99 min.
I = 7.83 max.
J = 9.53 min.
K = 10.37 max.
L = 12.07 min.

ISO PAD CALL OUT

- C1 V_{cc} (circuit supply voltage)
- C2 RST (reset signal)
- C3 CLK (clock signal)
- C4* RFU (reserved for future use)
- C5 GND (zero voltage)
- C6 V_{pp} (programming voltage)
- C7 I/O (data input/output)
- C8* RFU (reserved for future use)

*CNET POSITION: Identical to ISO position except C4 and C8 are not present on card or acceptor.

