

**13,5MM PITCH, 40A  
SERIES TSB1500**

**PHYSICAL PROPERTIES**

**Housing:**

HOUSING MATERIAL: Polyamide 6  
 FLAMMABILITY: UL94V-2  
 COLOR: Natural (off white)

**Terminal:**

TUBULAR CONTACT: Brass, tin plated  
 SCREW: Steel  
 SCREW PLATING: Zinc with chromate  
 WIRE PROTECTOR: Stainless steel  
 TUNNEL CONNECTION: Without wire protector

**Mechanical:**

PITCH (TERMINAL SPACING): 13.5mm (.532")  
 WIRE STRIP LENGTH: 8mm (.315")  
 RECOMMENDED TIGHTENING TORQUE: 10 in.-lbs.  
 RECOMMENDED SCREWDRIVERS: Stanley 1016,  
 Sears Craftsman 41429, Xcelite R184

**ELECTRICAL PROPERTIES:**

MAXIMUM CURRENT: 40A (UR); 55A (CSA)  
 OPERATING VOLTAGE: 300V

**WIRE RANGE:**

Wire Protector: 8-18 AWG  
 Tunnel Connection: 8-16 AWG

**ENVIRONMENTAL PROPERTIES:**

CONTINUOUS WORKING TEMPERATURE: 105°C

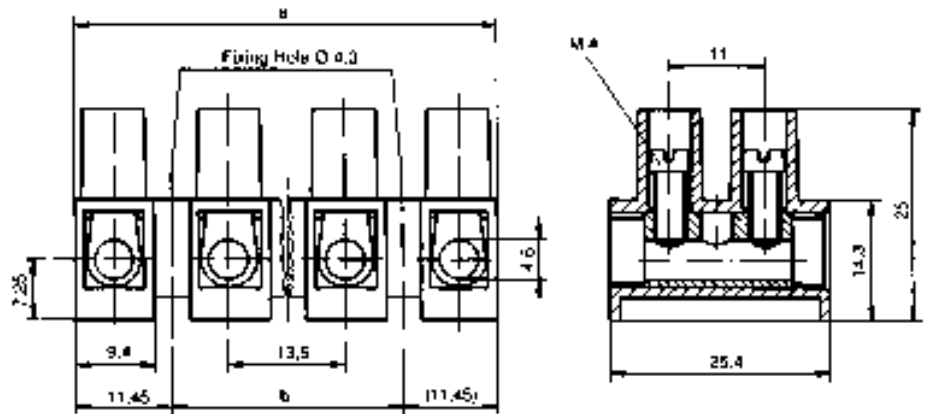
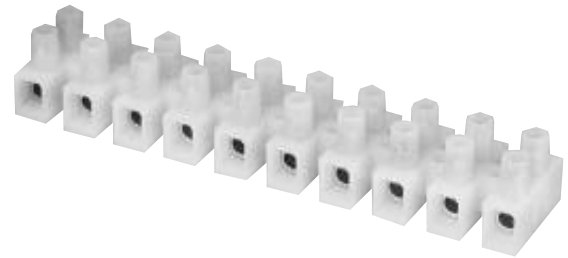

**Ordering Information**

NO. OF POS.	CATALOG NUMBER TUNNEL CONNECTION	CATALOG NUMBER WIRE PROTECTOR	A	B
1	TSB1500 01	TSB1500 01DS	9,4	—
2	TSB1500 02	TSB1500 02DS	22,9	—
3	TSB1500 03	TSB1500 03DS	36,4	13,5
4	TSB1500 04	TSB1500 04DS	49,9	27
5	TSB1500 05	TSB1500 05DS	63,4	40,5
6	TSB1500 06	TSB1500 06DS	76,9	54
7	TSB1500 07	TSB1500 07DS	90,4	67,5
8	TSB1500 08	TSB1500 08DS	103,9	81
9	TSB1500 09	TSB1500 09DS	117,4	94,5
10	TSB1500 10	TSB1500 10DS	130,9	108
11	TSB1500 11	TSB1500 11DS	144,4	121,5
12	TSB1500 12	TSB1500 12DS	157,9	135



LR28387 E63810