

BUSHINGS

*Available in the following materials:

Material Code No.	Material Name	Material Code No.	Material Name
-11	Polypropylene	-40	PFA, (Teflon®)
-18	Nylon 6/6, (natural)	-46	Polycarbonate
-27	PVC	-60	Nylon 6/6, 30% Short Glass-filled
-28	CPVC	-62	Acetal
-29	Teflon®	-194	Nylon 46, 30% Glass-filled, Heat Stabilized
-37	Kynar®, (PVDF)	-195	Nylon 46, 30% Glass-filled, Heat Stabilized, Fire Retardant\
-38	G-10 Fiber Glass		

*Available in other materials.
See materials list in index.

Call Crafterch for quote on BUSHINGS (pages 171 and 172).

Tell us Part No. and Material Code No. followed with dimensions to match line drawing (and drawing # if applicable).

COUNTERBORE BUSHINGS

Part No. DN198

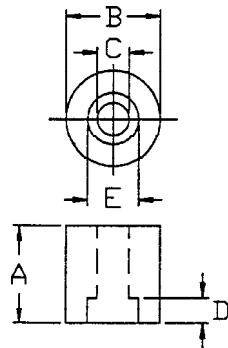

COUNTERSUNK BUSHINGS

Part No. D217

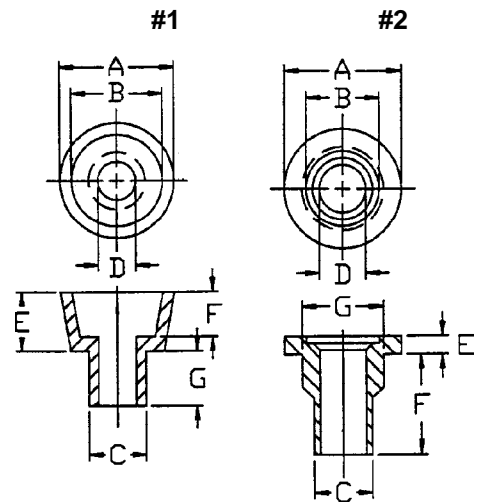

SPECIAL COUNTERBORE BUSHINGS

Part No. D216

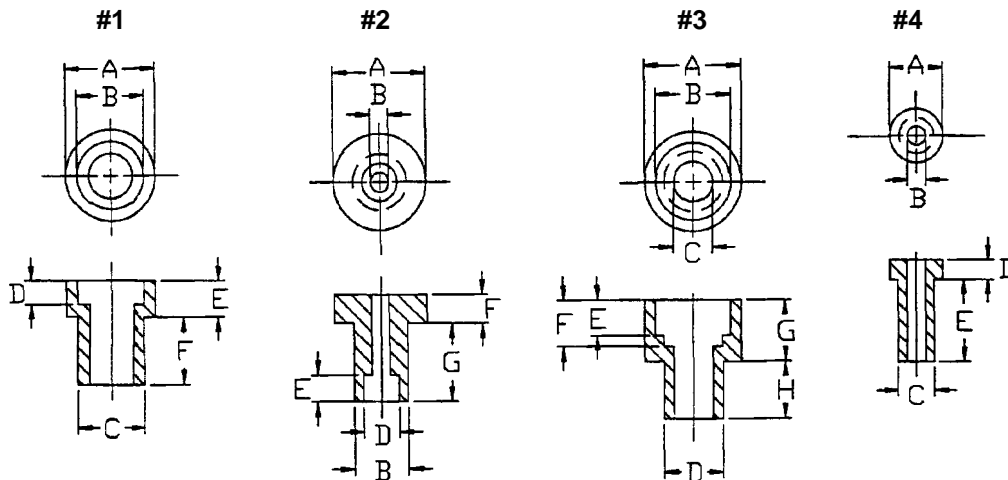

BUSHINGS (continued)

*Available in the following materials:

Material Code No.	Material Name	Material Code No.	Material Name
-11	Polypropylene	-40	PFA, (Teflon®)
-18	Nylon 6/6, (natural)	-46	Polycarbonate
-27	PVC	-60	Nylon 6/6, 30% Short Glass-filled
-28	CPVC	-62	Acetal
-29	Teflon®	-194	Nylon 46, 30% Glass-filled, Heat Stabilized
-37	Kynar®, (PVDF)	-195	Nylon 46, 30% Glass-filled, Heat Stabilized, Fire Retardent\
-38	G-10 Fiber Glass		

*Available in other materials.
See materials list in index.

Call Craftech for quote on BUSHINGS (pages 171 and 172).

Tell us Part No. and Material Code No. followed with dimensions to match line drawing (and drawing # if applicable).

CIRCUIT BOARD BUSHINGS

Part No. DN253

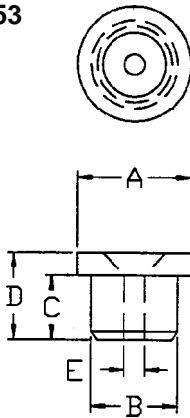

CIRCUIT BOARD PLUG BUSHINGS

Part No. DNF254

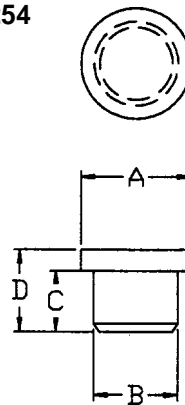

COUNTERSUNK CIRCUIT BOARD BUSHINGS

Part No. DN254

