

Flush-Mounted Panel Screw Components

Series CFS2, CFR2 & CFN2

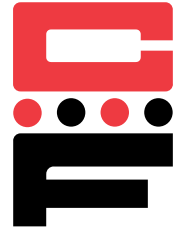

CFS2, CFR2 & CFN2 Panel Screw Components remain captive to panel and frame when unassembled. Panel Screws are designed to be flush in sheets as thin as .125 in. (3.2 mm.)

Series	Material	Finish
CFS2	300 Series Stainless Steel	Passivated ASTM A380
CFR2	300 Series Stainless Steel	Passivated ASTM A380
CFN2	Heat Treated Carbon Steel	Zinc Clear ASTM B633-85

Use in: materials of HRB 70 or less.

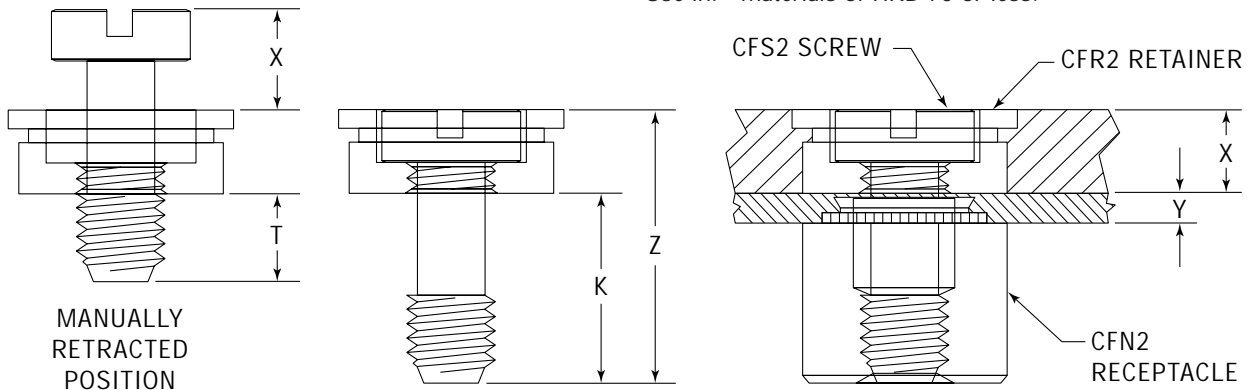

Dimensions & Specifications

INCH (in.)	Y	X	Z	H	K	D
	Max.	Nom.	$\pm .010$			Nom.
	0.04	0.125	0.40	0.16	0.28	0.13

Dimensions & Specifications

METRIC (mm)	Y	X	Z	H	K	D
	Max.	Nom.	± 0.25			Nom.
	1.0	3.18	10.3	3.8	7.2	3.3

Alternate Attachment Method:

When thin panel material makes it necessary for the screw head to remain above the top panel surface, CFS2 Screws may be used with CFL Flush Nuts as retainers. CFL nuts self-clinch into sheets as thin as .060 in. (1.5 mm) and remain flush on both sides of the panel. CFS2 Screws are rotated through the threads of the CFL Retainers to install and captivate. Refer to CFL section for dimensions and installation data.

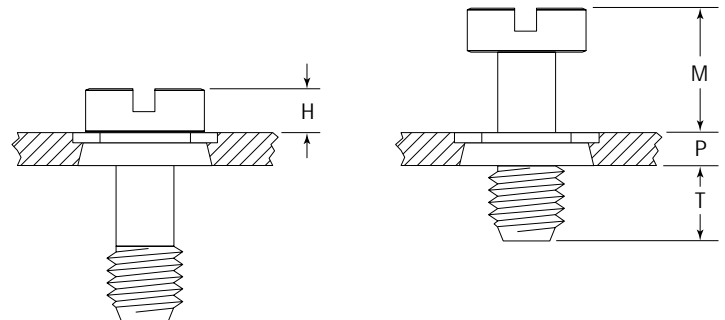

	P Max.	A	B	D Nom.
INCH (in.)				
CFS2 w/CFL Retainer	.060	.075	.210	.130
METRIC (mm)				
CFS2 w/CFL Retainer	1.50	1.90	5.40	3.30

Continued on next page.



Flush-Mounted Panel Screw Components

Series CFS2, CFR2 & CFN2

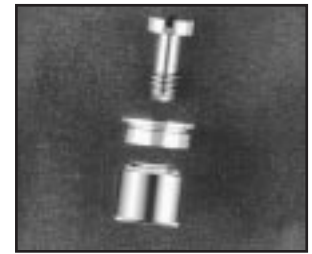

Continued from previous page.

Series CFS2 Flush-Mounted Screw

Part Number Structure:

CFS2 440-40

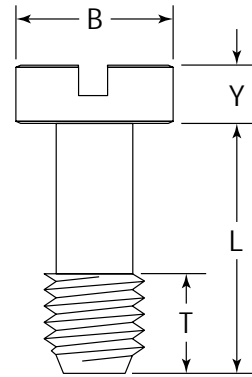
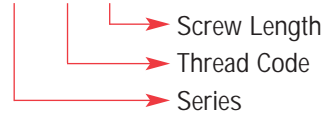

Dimensions & Specifications

INCH (in.)		Type	Thread Code	Screw Length Code	B Nom.	Y +.002 -.006	L ±.010	T Nom.
	Thread Size							
INCH (in.)	.112-40 (#4-40)	CFS2	440	40	.18	.075	.33	.13
	.138-32 (#6-32)	CFS2	632	40	.21	.075	.33	.13
	.164-32 (#8-32)	CFS2	832	40	.25	.075	.33	.13
	.190-32 (#10-32)	CFS2	032	40	.28	.075	.33	.13

Dimensions & Specifications

METRIC (mm)		Type	Thread Code	Screw Length Code	B Nom.	Y +0.05 -0.15	L ±0.25	T Nom.
	Thread Size							
METRIC (mm)	M3 x 0.5	CFS2	M3	40	4.7	1.9	8.3	3.3
	M4 x 0.7	CFS2	M4	40	6.3	1.9	8.3	3.3
	M5 x 0.8	CFS2	M5	40	7.1	1.9	8.3	3.3

Continued on next page.

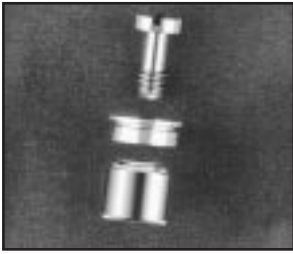

Flush-Mounted Panel Screw Components

Series CFS2, CFR2 & CFN2

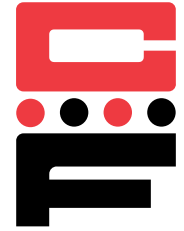

Continued from previous page.



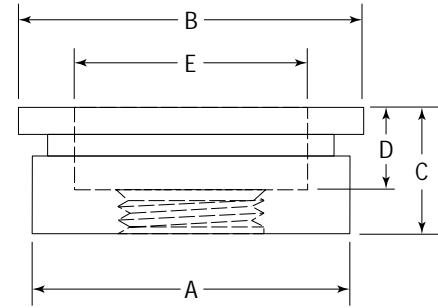

Series CFR2 Flush-Mounted Retainer

Part Number Structure:





CFR2 440



Dimensions & Specifications

												
	Thread Size	Type	Thread Code	C Max.	Min. Self-clinching	Min. Flush Install.	+0.003 -0.000	E Nom.	A Max.	B Nom.	D Nom.	Min.
INCH (in.)	.112-40 (#4-40)	CFR2	440	.124	.050	.125	.281	.195	.280	.310	.075	.310
	.138-32 (#6-32)	CFR2	632	.124	.050	.125	.312	.225	.311	.340	.075	.330
	.164-32 (#8-32)	CFR2	832	.124	.050	.125	.344	.225	.343	.370	.075	.340
	.190-32 (#10-32)	CFR2	032	.124	.050	.125	.375	.290	.374	.410	.075	.360

Dimensions & Specifications

												
	Thread Size	Type	Thread Code	C Max.	Min. Self-clinching	Min. Flush Install.	+0.08 -0.00	E Nom.	A Max.	B Nom.	D Nom.	Min.
METRIC (mm)	M3 x 0.5	CFR2	M3	3.15	1.40	3.20	7.10	5.00	7.08	7.90	2.0	7.90
	M4 x 0.7	CFR2	M4	3.15	1.40	3.20	8.75	6.50	8.71	9.50	2.0	8.70
	M5 x 0.8	CFR2	M5	3.15	1.40	3.20	9.50	7.40	9.47	10.30	2.0	9.20

Continued on next page.



Flush-Mounted Panel Screw Components

Series CFS2, CFR2 & CFN2

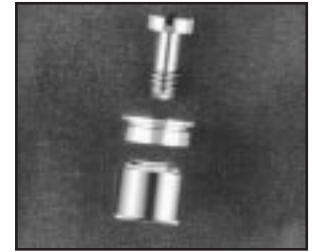

Continued from previous page.

Series CFN2 Self-Clinching Nut

Part Number Structure:

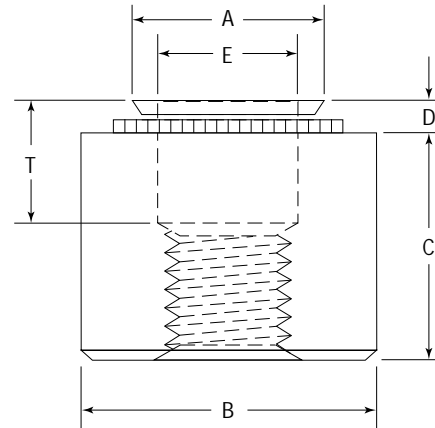
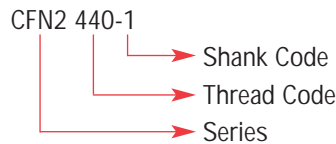

Dimensions & Specifications

	Thread Size	Type	Thread Code	Shank Code	D Max.	Min.	+0.003 -0.000	A Max.	B Nom.	T ±0.010	E Nom.	C ±0.005	Min.
INCH (in.)	.112-40 (#4-40)	CFN2	440	1	.038	.040	.187	.186	.280	.130	.120	.240	.220
	.138-32 (#6-32)	CFN2	632	1	.038	.040	.213	.212	.310	.130	.150	.240	.270
	.164-32 (#8-32)	CFN2	832	1	.038	.040	.250	.249	.340	.130	.180	.240	.280
	.190-32 (#10-32)	CFN2	032	1	.038	.040	.277	.276	.370	.130	.210	.240	.310

Dimensions & Specifications

	Thread Size	Type	Thread Code	Shank Code	D Max.	Min.	+0.08 -0.00	A Max.	B Nom.	T ±0.25	E Nom.	C ±0.13	Min.
METRIC (mm)	M3 x 0.5	CFN2	M3	1	0.97	1.00	4.75	4.73	7.10	3.30	3.20	6.00	7.90
	M4 x 0.7	CFN2	M4	1	0.97	1.00	6.40	6.38	8.70	3.30	4.70	6.00	8.70
	M5 x 0.8	CFN2	M5	1	0.97	1.00	7.00	6.96	9.50	3.30	5.40	6.00	9.20