

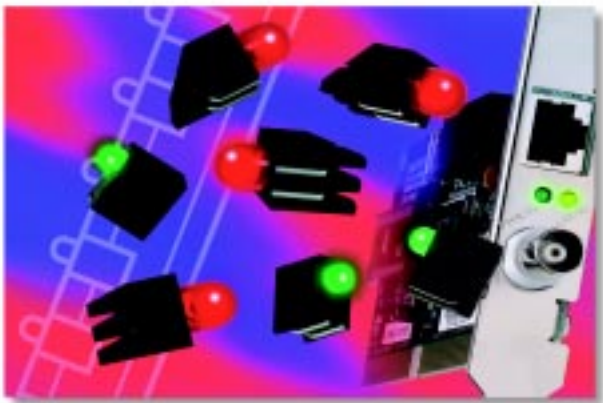

- **Standard Packaging**
- **Ideally Suited To IR-Reflow Soldering**
- **Wide Variety Of Colors And Brightness Levels**
- **Additional Configurations**

BivarOpto SMD LED Assemblies utilize industry standard packages reducing the need to reconfigure enclosures and front panels. Molded of a glass filled high-temperature material, SM200 & SM500 Assemblies are ideally suited to IR-Reflow soldering methods. Assemblies are available in a wide range of colors and brightness levels. Consult factory for additional configurations.



**Material Specifications:**

33% glass reinforced, flame retardant polyphthalamide (PPA)

Oxygen Index Rating: over 28%

**Standard Drawing Tolerances,**

Unless otherwise indicated:

Fractions: ± 1/64 (.40)

Decimals: 2 places, ± .010 (.25)

Angular: ±1°

Draft: 1% maximum

Gate Flash: .010 (.25)

MAXIMUM: .010 (.25) radii allowed on corners and edges.

**94V-0**

**U.L. RATED MATERIALS**

**SM200T  
SERIES**

*Tape and Reel Assembly*

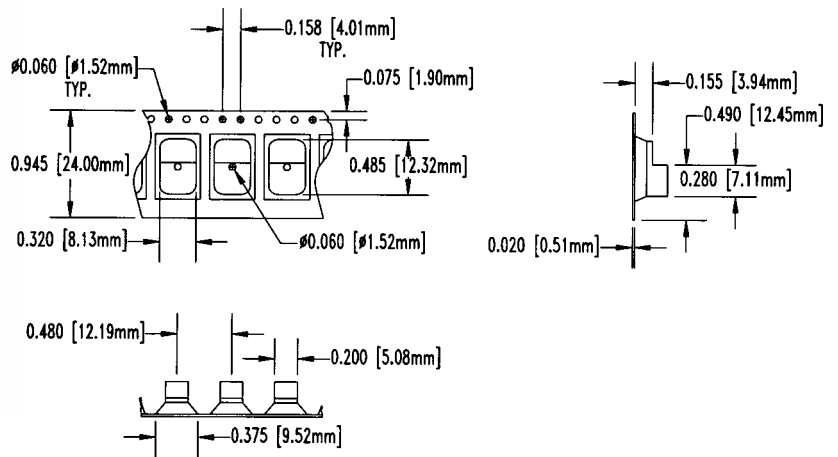

**SM500T  
SERIES**

*Tape and Reel Assembly*

